



Lytx[®] SF-Series Event Recorder Installation Instructions (North America Edition)

Last updated: 4/1/2019

THE DEVICE SHOULD BE INSTALLED AND MAINTAINED BY QUALIFIED TECHNICIANS. Only a properly qualified technician should install and maintain the SF-Series device. Any electrical work should be performed only by an ASE (minimum T6 & L2), MECP or equivalent certified technician with an expertise in installing and troubleshooting advanced vehicle onboard components including multiplexed circuits. Lytx, Inc. disclaims all responsibility for any damages arising from improper installation and maintenance of the SF-Series device.

This guide is protected as confidential and proprietary information of Lytx, Inc. Copying and use of this guide for any purpose other than installing SF-Series in vehicles of Lytx, Inc.'s customers is expressly prohibited. Information contained in this guide was in effect as of the date set forth above and is subject to change without notice or liability. Lytx, Inc. reserves the right to revise the information presented or to discontinue the production of parts described at any time.



Contents

Safety Instructions	4
Installation Safety Warnings	4
Driver Safety Warnings	4
Adherence to Applicable Local, State and Federal Laws	5
USA Federal Communications Commission (FCC) Notice	5
Canada – Industry Canada Notice	6
Suppliers Declaration of Conformance	7
Device Installation Overview	8
What’s Covered in the Installation Procedures	8
Installation Warnings	8
Before You Begin	8
Materials	9
Required Tools	11
Optional Tools	11
Optional Parts	11
Device Overview	12
Download and Install the Lytx Installation Tool	12
System Requirements for the Lytx Installation Tool	13
Instructions for Download and Installation	13
SF-Series Installation Procedures	15
Mount the Bracket and Event Recorder	15
Review Mounting Location Guidelines	16
Prepare the Mounting Location	18
Attach the Bracket and Event Recorder	19
Connect Electrical Wiring	19
Wiring Safety Warnings	20
Electrical Connection Overview Diagram	21
Wiring and Wire Termination Suggestions	23
Basic Event Recorder Electrical Connections	25
Connect to the Vehicle J1939 Network	27
Connect Turn Signals and Brake Inputs (ER-SF300 devices only)	28
Route the Device Power Cable	29
Run Testing and Complete Installation	30
Test Event Creation and Upload	31
Test Wire Connections and Settings in the Lytx Installation Tool	31
Camera Measurements (ER-SF300 devices only)	32
Initiate Diagnostic Mode	33
Complete Installation	34
Conduct Final Checks	34
Installation of Optional Parts	36
Overhead Mounting Bracket Installation Procedures	36



Materials	36
Attach the Overhead Mounting Bracket and Event Recorder	36
Extended Mounting Arm Installation Procedures	38
Materials	38
Mounting Arm Overview	38
Alternative Mounting Locations	38
Installation Instructions	39
Remote Push Button Installation Procedures	40
Materials	41
Mount the Remote Push Button	41
Assign the Input in the Lytx Installation Tool	41
Maintenance & Troubleshooting	42
Maintenance	42
Troubleshooting Installation Issues	42
Troubleshooting Issues After Installation	45
Initiate Diagnostic Mode	46
Troubleshooting in Diagnostic Mode	47
Uninstalling the Device	49
Materials	49
Instructions	49
Contact Technical Support	51



Safety Instructions

Installation Safety Warnings

Read and follow the instructions and precautions in this guide and all documents referenced in this guide when installing this device. Always refer to the vehicle manufacturer's service manual for proper installation and wiring of any aftermarket devices, including the SF-Series device. Failure to do so may result in property damage and/or personal injury.

WARNING: Park the vehicle on a level surface before beginning any maintenance or installation. Block the wheels to prevent the vehicle from moving. Never work under a vehicle supported only by jacks as jacks can slip and fall over.

WARNING: All wires that carry electrical current to the Lytx device must be fused. Failure to fuse the power, ground, and ignition wires can lead to serious personal injury and/or property damage. If any wires or cables containing fuses/fuse boxes need to be cut or otherwise shortened, always be certain to replace such fuses/fuse boxes or install new ones.

WARNING: Wire Protection: Take all necessary measures to protect all wire runs through a metal surface with a grommet or other device and all wire runs outside the vehicle cab with a loom. Always protect against wire fatigue and harness abrasion by properly attaching wires at closely spaced intervals, while avoiding contact with sharp edges or **doing anything else that might result in exposed wires**. All wires should be secured with tie wraps at least every one foot (30 cm/300 mm) or less. Do not over-tighten any tie wraps.

EXPLOSION HAZARD: Do not disconnect equipment unless power has been removed and the area is known to be non-hazardous.

WARNING: Substituting or supplementing components may impair suitability and performance. If you are missing any components contact Lytx Technical Support Center at 925.732.4246 or email support@lytx.com.

WARNING: Wear safe eye protection to prevent serious eye injury when you perform vehicle maintenance or service.

Driver Safety Warnings

WARNING: In order to reduce the potential danger of injuries, the driver and front passenger must always be correctly seated with seat belts correctly fastened when operating the vehicle.

DISCLAIMER: The Lytx Event Recorder is a driver aid only, not a substitute for a safe, conscientious driver. The Lytx Event Recorder cannot compensate for a driver who is distracted, inattentive or impaired by fatigue, drugs or alcohol. Whether or not the Lytx Event Recorder is in use, it is always the responsibility of the driver to take appropriate corrective action. Never wait for the device to provide a warning before taking measures to avoid an accident. Failure to do so can result in serious personal injury or death or severe property damage.



Always, it is the driver's responsibility to:

- Use safe driving techniques
- Exercise proper judgment
- Maintain a safe speed and distance between vehicles
- Take measures to avoid an accident
- Comply with all applicable laws and regulations

WARNING: In certain conditions, including inclement weather, low visibility, certain road conditions (including poor lane markings, construction zones, dirt roads, heavy or complicated traffic, and curvy and winding roads), the Lytx Event Recorder may have limited to no functionality. The Lytx Event Recorder may not detect certain objects such as motorcyclists, bicyclists or pedestrians even in the most ideal conditions. Always keep the lens and view of the Lytx Event Recorder unobstructed and properly calibrated so as not to inhibit function. Driving in certain conditions or any interference with the Lytx Event Recorder can result in false, few or no warnings. The driver must always monitor traffic and surroundings and take measures to avoid an accident; failure to do so can result in serious personal injury or death or severe property damage.

WARNING: If the Lytx Event Recorder is not functioning properly at any time, please contact your supervisor and have the device inspected immediately to correct the issue. Whether or not the Lytx Event Recorder is functioning, it is the driver's responsibility to maintain vehicle control; failure to do so can result in serious personal injury or death or severe property damage.

CAUTION: While cleaning the device or the vehicle cab, do not apply compressed air or cleaning solutions (such as Windex) to the Lytx device. Usage of these products may cause damage to the device.

WARNING: The optional livestream feature may have an approximate delay of 10 seconds. Livestream should never be used to assist the driver in operating the vehicle. The driver is responsible for the safe operation of the vehicle at all times and must always take measures to avoid a collision.

Adherence to Applicable Local, State and Federal Laws

WARNING: Some countries/regions/jurisdictions have adopted, or may in the future adopt, laws that prohibit objects from being mounted on a vehicle's windshield or other locations in a vehicle. You are responsible for complying with such laws, and Lytx, Inc. does not accept responsibility for your failure to do so.

USA Federal Communications Commission (FCC) Notice

This device complies with part 15 of the FCC Rules. Operation is subject to the following two conditions: (1) This device may not cause harmful interference, and (2) this device must accept any interference received, including interference that may cause undesired operation.



CAUTION: Changes or modifications to this product not expressly approved by Lytx, Inc. could void the user's authority to operate this equipment.

NOTE: This equipment has been tested and found to comply with the limits for a Class B digital device, pursuant to part 15 of the FCC Rules. This equipment generates, uses, and can radiate radio frequency energy and, if not installed and used in accordance with the instructions, may cause harmful interference to radio communications.

It is recommended that the antenna must not be co-located or operating in conjunction with any other antenna or radio transmitter.

CAUTION: Exposure to Radio Frequency Radiation. To comply with FCC RF exposure compliance requirements, for mobile configurations, a separation distance of at least 20 cm must be maintained between the antenna of this device and all persons. This device must not be co-located or operating in conjunction with any other antenna or transmitter.

Canada – Industry Canada Notice

This device complies with Industry Canada license-exempt RSS standard(s). Operation is subject to the following two conditions: (1) This device may not cause harmful interference, and (2) this device must accept any interference received, including interference that may cause undesired operation.

This Class B digital apparatus complies with Canadian ICES-003.

Cet appareil est conforme aux normes RSS exemptes de licence d'Industrie Canada. Son utilisation est soumise aux deux conditions suivantes: (1) Cet appareil ne doit pas causer d'interférences nuisibles et (2) cet appareil doit accepter toute interférence reçue, y compris les interférences susceptibles de provoquer un fonctionnement indésirable.

Cet appareil numérique de la classe B est conforme à la norme NMB-003 du Canada.

CAUTION: Exposure to Radio Frequency Radiation. To comply with RSS 102 RF exposure compliance requirements, for mobile configurations, a separation distance of at least 20 cm must be maintained between the antenna of this device and all persons. This device must not be co-located or operating in conjunction with any other antenna or transmitter.

Pour se conformer aux exigences de conformité 102 RSS RF exposition, pour des configurations mobiles, une distance de séparation d'au moins 20 cm doit être maintenue entre l'antenne de cet appareil et toutes les personnes. Cet appareil ne doit pas être co-localisés ou fonctionnant en conjonction avec une autre antenne ou transmetteur.



Suppliers Declaration of Conformance

We, Lytx, Inc., hereby declare that the product listed below, to which this Declaration of Conformity relates, is in conformity with the Standards and other Normative Documents listed below:

Manufacturer's Name & Address:

Lytx, Inc.
9785 Towne Centre Drive
San Diego, CA 92121 USA

Declares that the following product:

Product Name: Video Event Recorder

Product Model:

- ER-SF1 (DC-6000-001)
- ER-SF64 (DC-6000-001)
- ER-SF300 (DC-6000-030)

The product specified above carries the marking, by complying with the essential requirements and provisions. Conformity is based upon the following standards:

Manufacturer's Contact:

Lytx, Inc.
9785 Towne Centre Drive
San Diego, CA 92121 USA
Phone Number: (858) 430-4000
Fax Number: (858) 430-4001

EMC & Radio:

CFR Title 47 FCC Part 15, Subpart B and C,
Class B

Industry Canada ICES-003, Class B

Industry Canada RSS-Gen

Industry Canada RSS-210 (applicable only to
cellular modem variant)

Industry Canada RSS-247

Mexico IFETEL

Mexico NOM-001-SCFI-1993



Device Installation Overview

What's Covered in the Installation Procedures

The following instructions are for installation of the Lytx SF-Series event recorder with optional ECM connectivity for ECM data collection. These instructions cover these sections:

1. Mounting of the device using the standard method
2. Electrical connections and cable routing
3. Testing

These instructions also cover installation of these optional parts:

- Overhead Mounting Bracket
- Extended Mounting Arm
- Remote Push Button

Installation Warnings

THE DEVICE SHOULD BE INSTALLED AND MAINTAINED BY QUALIFIED TECHNICIANS. Only a properly qualified technician should install and maintain the SF-Series device. Any electrical work should be performed only by an ASE (minimum T6 & L2), MECP or equivalent certified technician with an expertise in installing and troubleshooting advanced vehicle onboard components including multiplexed circuits. Lytx, Inc. disclaims all responsibility for any damages arising from improper installation and maintenance of the SF-Series device.

THIS GUIDE IS NOT A SUBSTITUTE FOR A QUALIFIED TECHNICIAN.

THE DEVICE SHOULD NOT INTERFERE WITH THE VEHICLE'S COMPUTER SYSTEMS. The SF-Series device interfaces with the vehicle's computer systems to capture data for safety analysis. However, it should not interfere with any of the vehicle's computer systems. If there is a malfunction of the vehicle's computer systems after installation, contact Lytx Technical Support Center at 925.732.4246 or email support@lytx.com immediately. Lytx recommends that you do not drive the vehicle until the malfunction is resolved. Lytx, Inc. disclaims all responsibility for any damages arising from improper installation and maintenance of the SF-Series device.

Before You Begin

1. **Read and understand all instructions and procedures provided for the vehicle and the SF-Series device.** This guide must be read in conjunction with the vehicle manufacturer's service manual, the Mounting Regulations, all instructions and procedures issued by Lytx, Inc., and any applicable federal, state, provincial and local laws that prohibit mounting devices on vehicle's windshield or other locations in a vehicle.



2. **Read and observe all warnings, cautions, and safety notices** in the instructions and procedures. They provide information to avoid serious personal injury, damage to components or both.
3. **Follow the vehicle's maintenance, service, installation and diagnostic guidelines** provided by the manufacturer of the vehicle.
4. **Check for laws or regulations that prohibit objects from being mounted on a vehicle's windshield** or other locations in a vehicle. You are responsible for complying with such laws and regulations, and Lytx, Inc. does not accept responsibility for your failure to do so.
5. **Use special tools and safety equipment** to avoid serious personal injury and damage to components.

Materials

The following materials are included in your SF-Series Event Recorder kit:

	
SF-Series unit	Standard mounting bracket
	
Two (2) T-27 security Torx screws One (1) T-8 security Torx screw	Alcohol wipe

For standard, power-only installations:

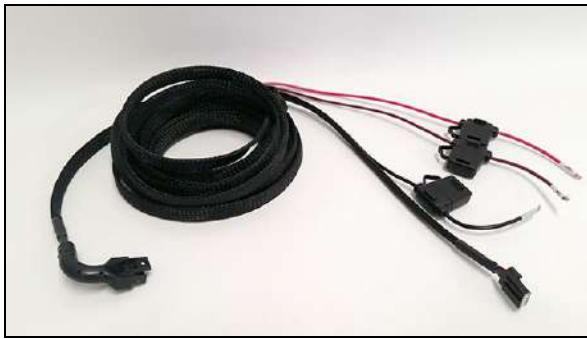

Non-ECM, Device Power Only Cable with inline fuses:
 Red and Black wires = 5-amp fuses
 Brown wire = 1-amp fuse



Tamper Prevention Clip

For installations including J1939 and/or ActiveVision connections:



Device Power Cable



Vehicle Interface Cable with inline fuses:
 Red and Black wires = 5-amp fuses
 Brown wire = 1-amp fuse



J1939 CAN Coupler
 Only included in kits for J1939 networks



Tamper Prevention Clip



If you are missing any materials, contact the Lytx Technical Support Center at 925.732.4246 or email support@lytx.com to obtain the necessary materials before beginning installation. Supplementing or substituting shipped materials could impair suitability and performance.

Required Tools

In addition to all guides and reference documents that you should read before beginning installation, the following tools are required for installation:

- Wire cutter
- Wire crimper
- Voltmeter or multimeter
- Vehicle panel removal tool
- Flat-blade screwdriver
- Cable ties
- Phillips screwdriver
- Electric tape
- Tape measure
- Marking pen
- T-27 security Torx bit
- T-8 security Torx bit
- Micro USB cable
- Vehicle manufacturer recommended tools

Consult the vehicle's maintenance, service, installation, and diagnostic guidelines provided by the manufacturer of the vehicle for any additional tools needed.

Optional Tools

The following tools are not required for installation but can be helpful:

- Cordless driver
- Add-a-circuits or vehicle-specific connectors
- Grommets and looms
- Flashlight
- Paper towels/shop towel
- Utility knife
- Vehicle-specific panel clips
- Heating torch
- Heat shrink
- Soldering iron
- Solder
- Self-amalgamating tape

Optional Parts

The following optional parts may be purchased from Lytx:

- Overhead Mounting Bracket
- Extended Mounting Arm
- Remote Push Button (Standard)
- Clamshell Security Cover (Both Lenses)
- Power Cable Extension (20-ft)

Device Overview

ER-SF1 and ER-SF64 devices:

1. Interior-facing lens
2. Microphone
3. LED status lights
4. Manual record buttons
5. Serial number (on side of device)
6. Exterior-facing lens
7. Micro-USB port
8. Device Power Cable port
9. SIM card port

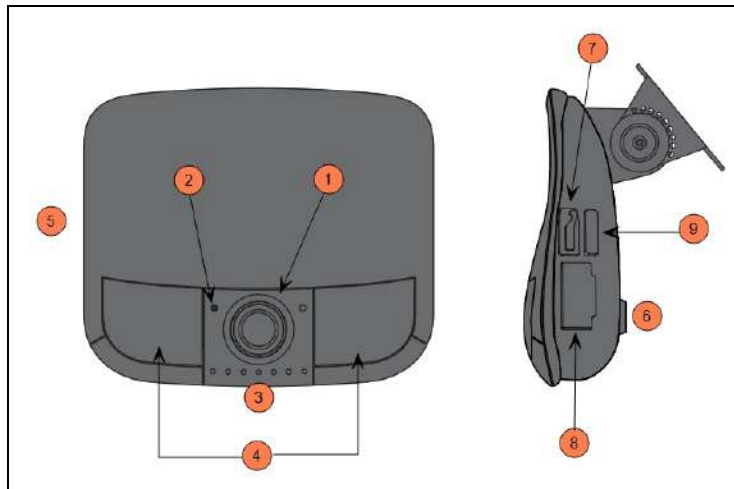

ER-SF300 devices:

1. Interior-facing lens
2. Microphone
3. Ambient light sensor
4. LED status lights
5. Manual record buttons
6. Serial number (on side of device)
7. Exterior-facing lens
8. Micro-USB port
9. Device Power Cable port
10. SIM card and SD card port

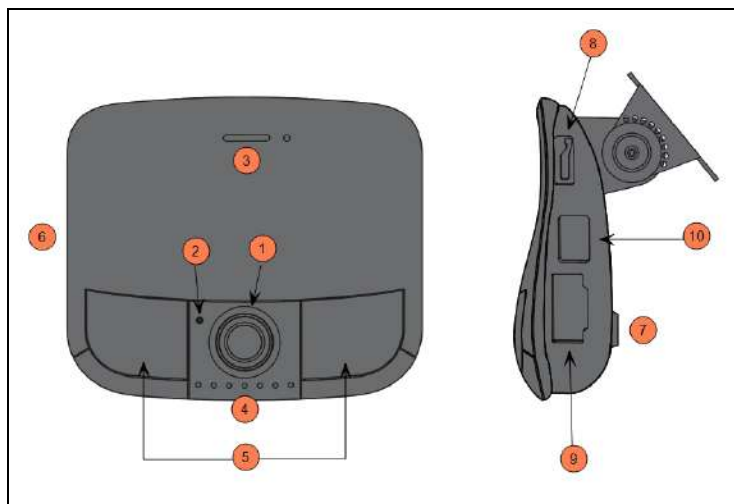

Download and Install the Lytx Installation Tool

The Lytx Installation Tool is a software wizard that walks you through device testing step-by-step at the end of installation. If this tool hasn't already been downloaded and installed on your laptop prior to device installation, follow the steps below.

Obtain the Job File

In addition to downloading and installing the Lytx Installation Tool, you must also obtain the correct job file prior to device installation. Obtain this from the client's Implementation Services Specialist.

System Requirements for the Lytx Installation Tool

Before installation, ensure your laptop meets these minimum requirements:

- Operating System: Windows 8 or newer
- Hard drive space: 256 MB
- USB port

Instructions for Download and Installation

1. Using the Internet Explorer browser, log into the DriveCam Online® portal. In the upper-right corner, click on Learning Center.

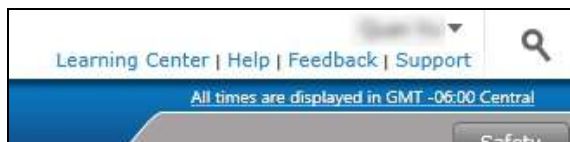

2. Go to My Learnings. Then go to My Learning Paths.



3. Browse and find the learning path, Lytx Installation Tool. Press Start.



4. Browse and find the course for "Lytx Installation Tool Download". Press Register. Then press Start.



5. Download the installation file to your computer.
6. Open the file. Follow the prompts to install the tool.



SF-Series Installation Procedures

Installation of the SF-Series event recorder consists of these main sections. Each section has its own subsections as well:

Mount the Bracket and Event Recorder	15
Connect Electrical Wiring	19
Run Testing and Complete Installation	30

Pre-Installation Check

Before beginning the installation, turn the vehicle on. Verify that no Check Engine lights, error codes, or warnings appear on the gauge console, dashboard, or vehicle display. It may be necessary to cycle through displayed messages or screens to verify.

If any Check Engine lights, error codes, or warnings appear, report these to the site contact before proceeding.

Mount the Bracket and Event Recorder

WARNING: Before mounting the bracket and event recorder, consult the vehicle manufacturer's recommendations and any applicable federal, state, provincial and local laws that restrict mounting devices on a vehicle's windshield or other locations in a vehicle.

Mounting the bracket and event recorder consists of these subsections:

1. Review Mounting Location Guidelines
 - a. Mounting Location Recommendations and Restrictions
2. Prepare the Mounting Location
3. Attach the Bracket and Event Recorder

Alternative Mounting Methods

The subsections, "[Prepare the Mounting Location](#)" on page 18 and "[Attach the Bracket and Event Recorder](#)" on page 19, cover the recommended standard windshield mounting method only. However, if windshield mounting is not possible/permitted in the vehicle or jurisdiction, alternative mounting methods are available. For instructions on alternative mounting methods, please review the mounting location guidelines and see "[Installation of Optional Parts](#)" on page 36.

Review Mounting Location Guidelines

CAUTION: An improperly positioned event recorder can reduce program effectiveness.

The event recorder should be mounted in a location that provides an unobstructed view of the driver and the road in front of the vehicle.

1. **Interior-facing Lens View:** Should span from the outside shoulder of the driver to the outside shoulder of a front seat passenger. If possible, it should show the lap band of the seat-belt.
2. **Exterior-facing Lens View**
 - a. Should be inside the path of the wiper blades.
 - b. Should capture a clear view of everything in front of the vehicle, beginning as close to the front of the vehicle as possible without cutting off the horizon.



To use the event recorder to temporarily gauge the best position, first loosen the Torx screws so the event recorder can rotate in the bracket. Then hold it up to the windshield.

Mounting Location Recommendations and Restrictions

WARNING: Some countries/regions have adopted laws that restrict locations where objects can be attached to the vehicle windshield. Always refer to any applicable federal, state, provincial and local laws that concern mounting devices on vehicle windshields or other locations in a vehicle before choosing a mounting location.

The figures below provide guidelines for mounting the event recorder on the vehicle windshield that work within the regulations set forth by the U.S. Department of Transportation, Federal Motor Carrier Safety Administration (FMCSA)*.

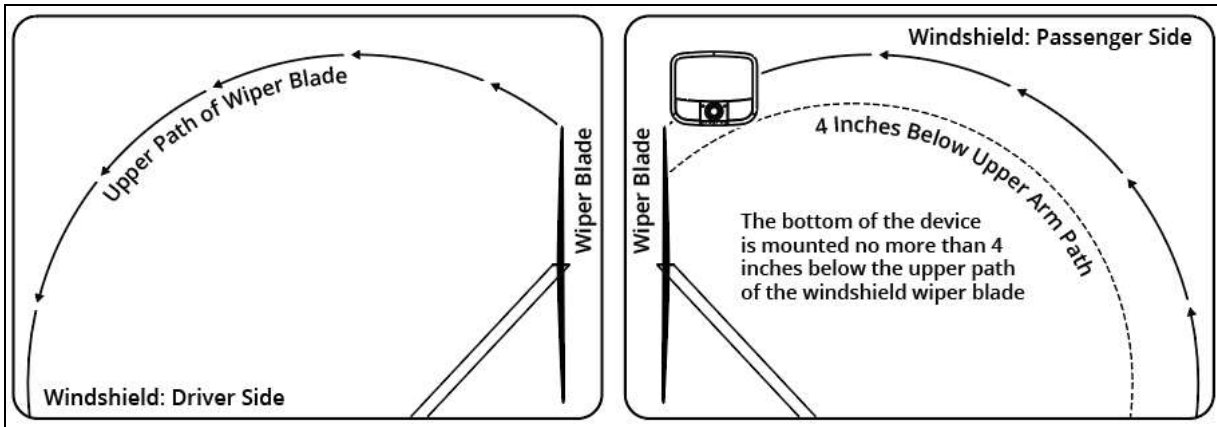
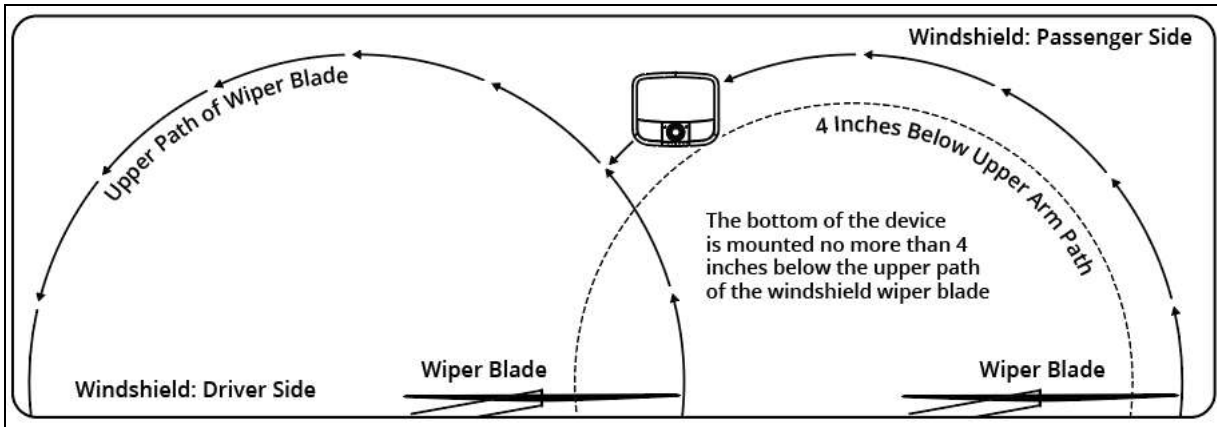

*The FMCSA regulations allow the event recorder to be mounted not more than 100 mm (4 inches) below the upper edge of the area swept by the windshield wipers or not more than 175 mm (7 inches) above the lower edge of the area swept by the windshield wipers, provided that the event recorder is located outside the driver's sight lines to the road and highway signs and signals. See 49 C.F.R. § 393.60(e).

Prepare the Mounting Location

CAUTION: To mount the device, the air temperature must be at least 50°F (10°C). The ideal temperature range is 70-100°F (21-38°C).

CAUTION: Do not use a heat torch to heat up the windshield or adhesive on the bracket as this may reduce bracket adherence. If additional heat is required, use the vehicle heating system for the windshield.

CAUTION: Steps 1-3, cleaning the area and drying it, are critical to prevent the bracket from falling off later.

CAUTION: Do not peel the backing from the bracket's adhesive in this section.

1. Apply isopropyl alcohol on the windshield mounting area and dry it off with a clean cloth, removing any debris. This is the area behind the rear view mirror on the passenger side or the equivalent area if there is no rear view mirror (see below).
2. Clean the mounting area again with the Lytx-supplied alcohol wipe.
3. Wait 2 minutes for the mounting area to air dry before applying the device bracket. **Do not dry it with a cloth.**

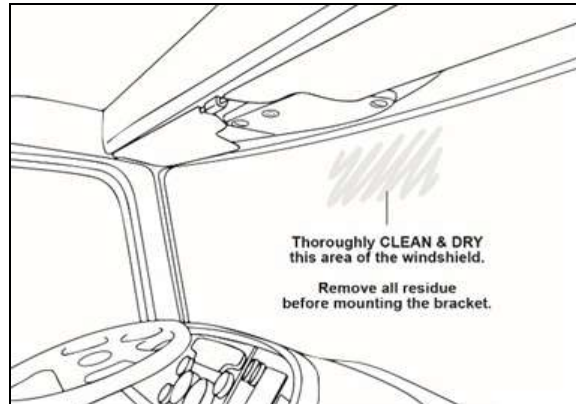

4. Following the mounting location guidelines above, hold the assembly in place and trace the outline of the bracket on the windshield with a marker. Make sure the traced guide marks are level.

5. Remove the event recorder from the mounting bracket.
6. Check the fit of the bracket against the windshield. If the windshield is curved, you may gently bend the bracket so it lies flush against the glass.

Best practice: Select a surface location with minimal curvature.

7. Check again to make sure you've selected the best mounting location.
 - a. Sit in the driver's seat while holding the device up. Make sure it doesn't block the driver's view of the road.
 - b. Turn on the wipers and rotate mirrors, sun visors, and other objects near the device to make sure they cannot block either lens.

Attach the Bracket and Event Recorder

CAUTION: The adhesive is very sticky. Once applied, it will not easily come off. Take care to attach the bracket to the mounting location properly.

CAUTION: Do not apply excessive pressure as it may cause the windshield to break.

CAUTION: After removing the backing from the bracket's adhesive, apply the bracket to the windshield immediately. If you leave the adhesive exposed for too long, it may be compromised.

1. Remove the backing from the adhesive side of the bracket. Carefully attach the bracket to the windshield.
 - a. Place the left edge of the bracket against the windshield, aligned with the marks, and make sure it is level.
 - b. Press the bracket firmly against the windshield starting at the left and pressing downward to the right.
2. Check from outside the vehicle for large air bubbles under the bracket. If you find any:
 - a. Apply additional pressure to the bracket.
 - b. Slide a pin between the bracket and windshield to let out the air.
3. Wait 10 minutes to allow the bracket's adhesive to bond.
4. Place the event recorder in the bracket.
5. Adjust the event recorder so it hangs vertically (plumb). See Figure C.
6. Secure the event recorder in the bracket using the two T-27 Torx screws.

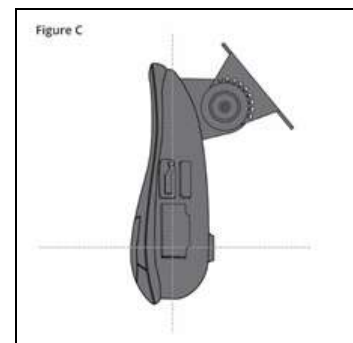
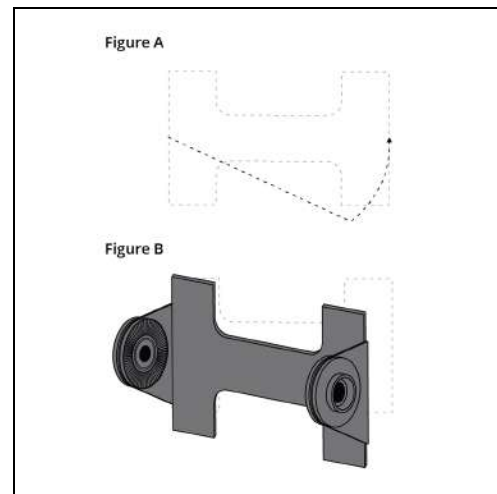

Connect Electrical Wiring

Connecting the electrical wiring consists of these subsections:

Wiring Safety Warnings	20
Electrical Connection Overview Diagram	21
Wiring and Wire Termination Suggestions	23
Basic Event Recorder Electrical Connections	25



Connect to the Vehicle J1939 Network	27
Connect Turn Signals and Brake Inputs (ER-SF300 devices only)	28
Route the Device Power Cable	29

Wiring Safety Warnings

WARNING: Only approved wire connection methods are recommended. Refer to the vehicle manufacturer’s service manual to determine if soldering, sealing crimp connections, Add-A-Circuit, Posi-Tap, sealing butt connections, or OEM connections to open connection ports are approved. Never use plier tap products such as insulation displacement connectors (i.e. ScotchLoc connectors) when installing the SF-Series.

WARNING: Never wire the SF-Series device in a manner that shares a connection with another aftermarket product in the vehicle. Independent connections should always be used.

WARNING: All wires that carry electrical current to the Lytx device must be fused. Failure to fuse the power, ground, and ignition wires can lead to serious personal injury and/or property damage. If any wires or cables containing fuses/fuse boxes need to be cut or otherwise shortened, always be certain to replace such fuses/fuse boxes or install new ones.

WARNING: Wire Protection: Take all necessary measures to protect all wire runs through a metal surface with a grommet or other device and all wire runs outside the vehicle cab with a loom. Always protect against wire fatigue and harness abrasion by properly attaching wires at closely spaced intervals, while avoiding contact with sharp edges or **doing anything else that might result in exposed wires**. All wires should be secured with tie wraps at least every one foot (30 cm/300 mm) or less. Do not over-tighten any tie wraps.

WARNING: Cable Routing: Make certain that neither the cable nor your installation activities interferes with any airbag-related mechanisms or otherwise risks affecting airbag deployment. Consult the vehicle manufacturer for the location of any airbag sensors and systems and restrictions that may apply.

Electrical Connection Overview Diagram

For standard, power-only installations:

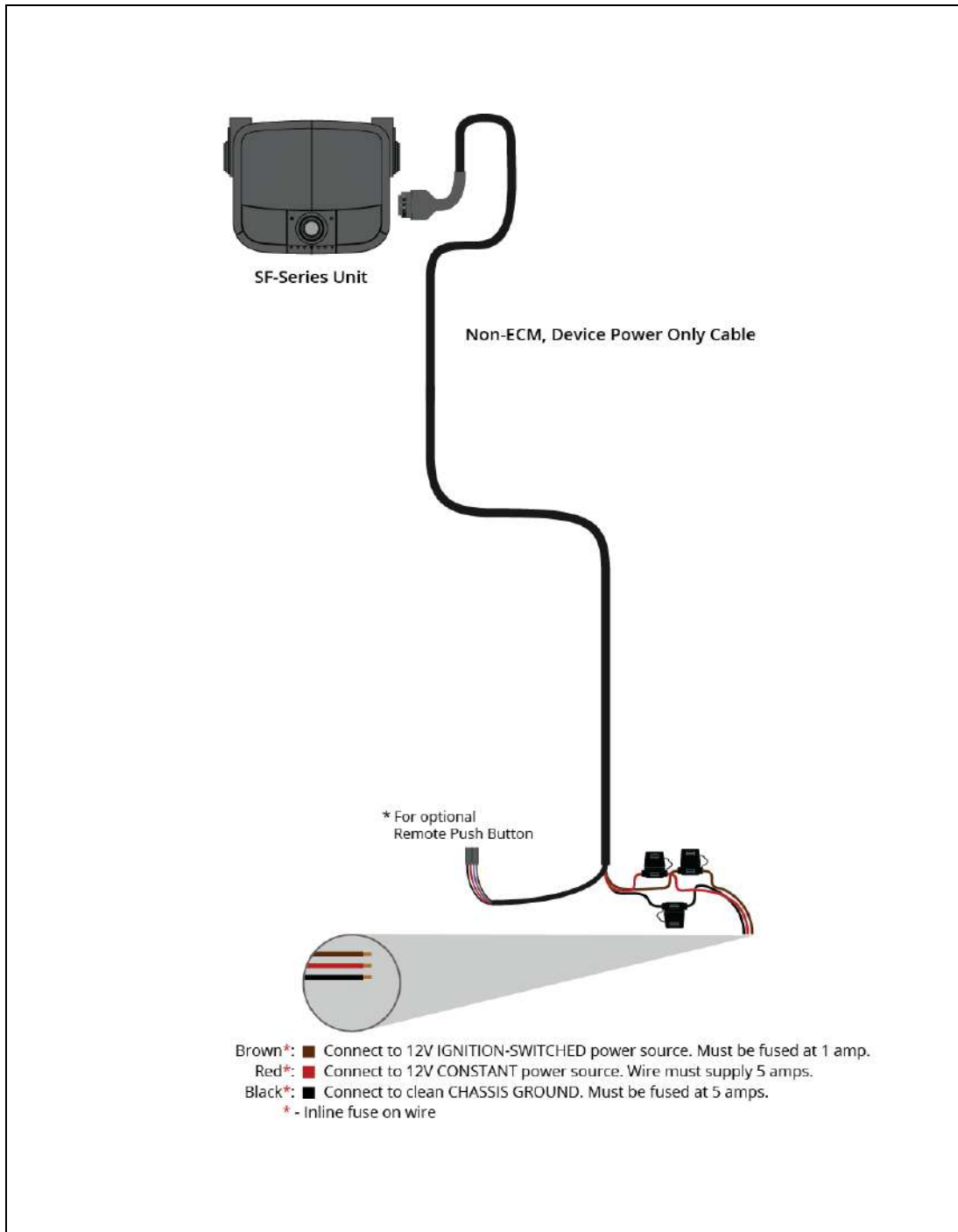

For installations with J1939 and/or ActiveVision connections:

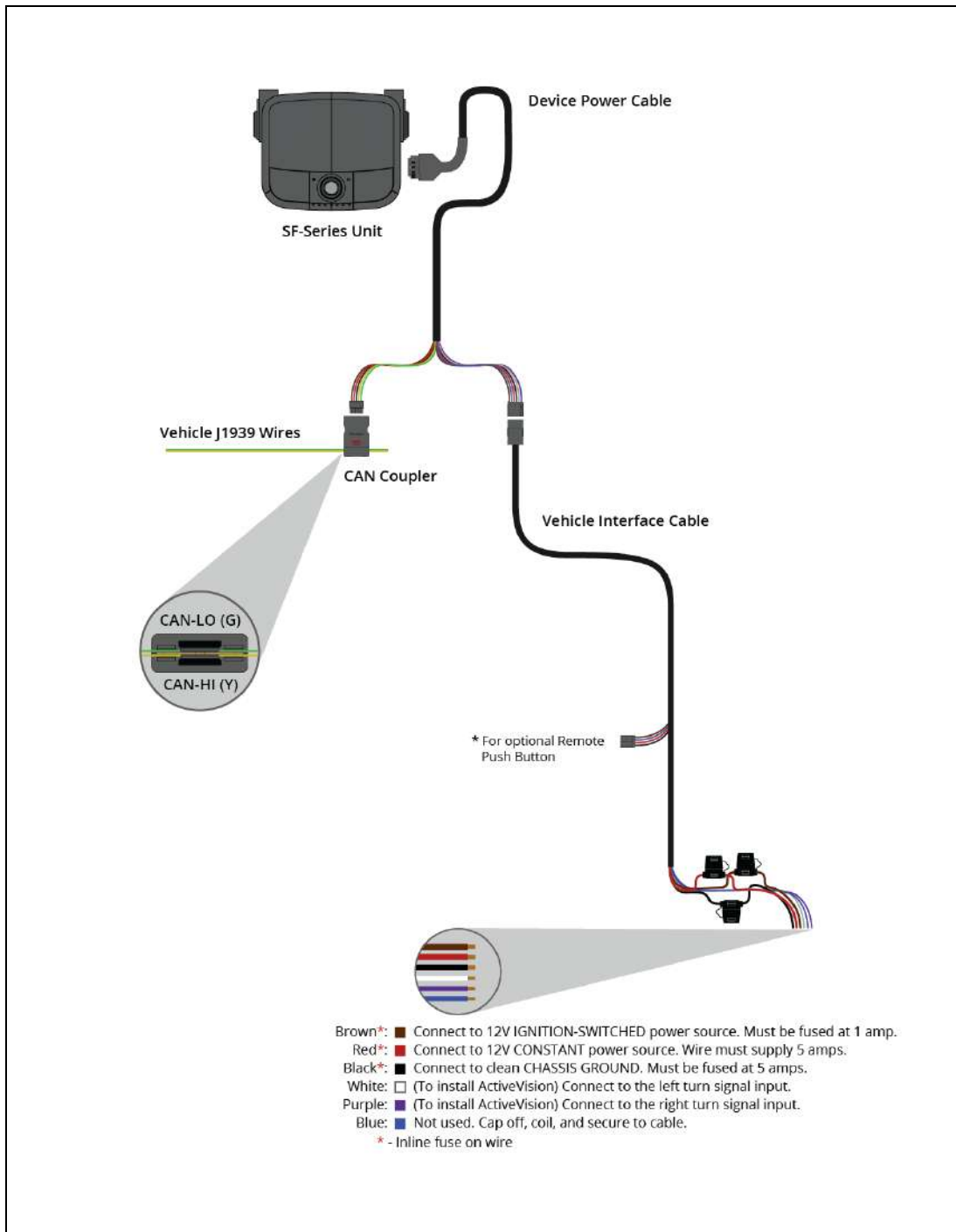

Wiring and Wire Termination Suggestions

WARNING: Failure to use proper wiring and wire terminations could lead to personal injury or property damage. The following Wire Termination Suggestions should be followed to ensure proper connections.

When installing the event recorder, there are several key rules to produce reliable electrical connections.

1. **Prohibited connectors:** The use of insulation displacement connectors (i.e. ScotchLoc connectors) (Fig. A), unsealed quick slide/spade connectors (Fig. B), and non-sealing butt connectors is prohibited. In addition, the use of fuse taps on ECM, ECU, or control module circuit fuses is prohibited.

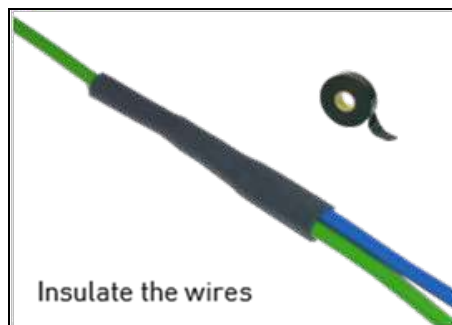
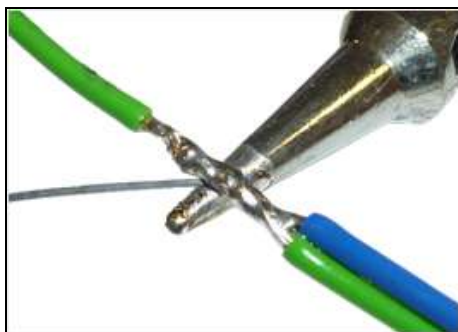

Fig. A



Fig. B

2. **Use ONLY 16-gauge automotive primary wire to connect to automotive circuits.** Specialty wire might be superior when used in its native environment, but not in the automotive field. (For example, Teflon wire is intended for high heat conditions, but should never be used for connections of the event recorder in the vehicle.)
3. For all connection methods, **do not leave any exposed wire near the connector.**
4. **Solder joints:** All solder joints **MUST** be insulated by either self-amalgamating tape (and over loomed with insulation or cloth tape) or adhesive-lined heat shrink.



5. **Posi-Tap connectors:** Posi-Tap wiretap connectors may only be used inside the cab of the vehicle and only for event recorder inputs such as ignition. They cannot be used for constant power or ground. The Posi-Tap connectors must be the proper gauge size for the wire it's connecting to.

- 6. **Crimp style connectors:** All crimp style connectors must be the sealing type. Verify the crimped connection is secure. Then heat up the connector to melt and seal it.

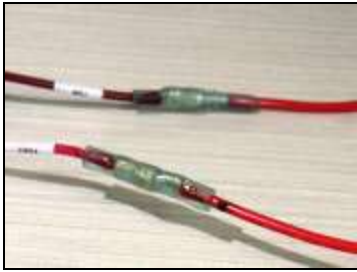

- 7. **Fuse taps/Add-A-Circuits:** If using a fuse tap (Add-A-Circuit), make sure to test with a meter that the circuits only share the hot leg of the fuse receptacle to ensure the circuits are separately fused. If installed backwards, a fuse tap will compromise the original circuit. Below is one example:

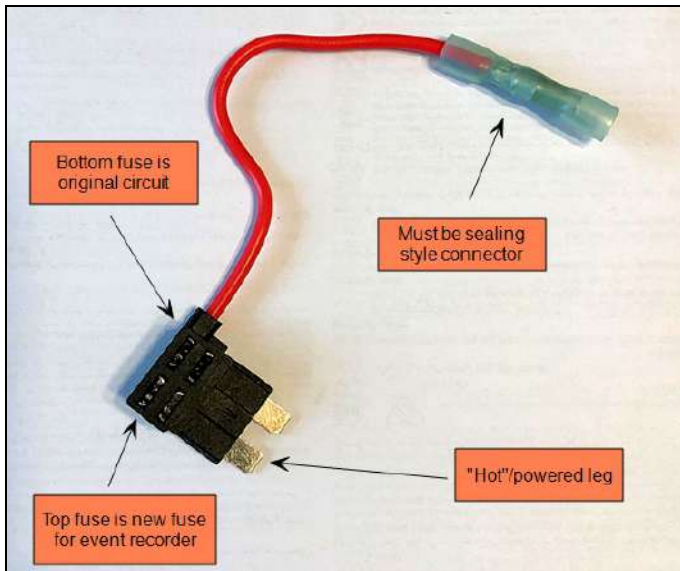

Refer to the "Fuse Taps/Add-A-Circuits Suggestions" section below for more information.

- 8. **Quick slide/spade connectors:** Quick slide/spade connectors may be used only if they are either properly insulated OR they are sealed with heat shrink. Otherwise, these may not be used.



Fuse Taps/Add-A-Circuits Suggestions

If you're connecting fuse taps/Add-A-Circuits to the fuse panel, use the following criteria to select appropriate locations for the Constant Power and Ignition connections.

1. Connect to open circuits without a fuse already in place, if available.
2. Connect to slots for non-critical functions (e.g. radio or power windows). Avoid connecting to critical functions (e.g. airbags or control modules) as this may cause the vehicle to be inoperable and/or create a safety hazard. Refer to the examples below.

Best slots:

- radio
- power outlet
- heated seats
- power seats
- power windows
- upfitter/auxiliary options

Slots to avoid:

- control modules (ECM, BCM, TCM, etc.)
- lights (headlights, taillights, brake, hazards)
- airbags
- horn
- fuel pump

Good slots:

- power mirrors
- HVAC controls

Basic Event Recorder Electrical Connections

A minimum of three connections are required for the event recorder to function. These leads are found on the Vehicle Interface Cable/Non-ECM, Device Power Only Cable terminating at the female end of the Molex connector.

1. **Red wire:** Provides primary power and must be connected to a continuous power source. This lead has a 5-amp inline fuse.
2. **Brown wire:** Functions as an ignition-sense, used by the event recorder to perform functions such as activating the Infrared Illuminator when the vehicle ignition is switched on or activating Hibernation mode when the ignition is switched off. This lead has a 1-amp inline fuse.
3. **Black wire:** Functions as ground. This lead has a 5-amp inline fuse.





Connect the RED WIRE to a 12V/24V Power Source that's ALWAYS ON

CAUTION: This is a fused connection. Do NOT cut off or remove the inline fuse.

The event recorder always remains “on.” This requires a 12V or 24V power source that is not controlled by the key nor any other device or switch. Typically, this connection is made just after the fuse box on the battery-side of any vehicle control modules. Use a voltmeter to make sure the circuit provides continuous 12V or 24V power when the key is removed from the ignition and all lights, devices and switches are off.

Ensure Sufficient Current Draw

If you're tapping into an existing vehicle wire, make sure it can handle the additional current draw of the event recorder. A wire that reads 12V or 24V on a voltmeter may not necessarily be able to supply enough current to the existing circuit and the event recorder. The gauge of wire being tapped into provides a good indication. A larger gauge wire is often the best choice.

Connect the BROWN WIRE to 12V/24V Power Source that's IGNITION-SWITCHED

CAUTION: This is a fused connection. Do NOT cut off or remove the inline fuse.

CAUTION: The brown wire to a 12V or 24V power source that is ignition-switched is important to ensure the event recorder can identify when the ignition is switched on and off and to control the event recorder's Hibernation mode. This connection requires a 12V or 24V power source that is “on” either when the ignition is keyed all the way forward to the ON position and all the way back to the OFF position. Failure to properly connect this fused connection may lead to vehicle battery drain.

Note for Brown Wire Connections

Connect this wire to a circuit that is on the battery side of any modules. Consult the vehicle wiring schematics or a local authorized dealership to obtain this information. Ensure that you do not make a connection to a modulated circuit—one that comes out of a computer control module running some subsystem in the vehicle. This can give false ignition on/off signals.

Connect the BLACK WIRE to a Good Solid Vehicle Ground

CAUTION: This is a fused connection. Do NOT cut off or remove the inline fuse.



This connection is usually made via ring terminal to ground lug in the vehicle, supplied by the vehicle manufacturer for aftermarket products. If one is not available, ensure that the connection is solid to a metal portion of the vehicle which is directly grounded to the vehicle frame. Ensure there is no corrosion or paint interfering with this connection.

Instructions for Basic Connections

1. Find a suitable location to make electrical connections (usually behind/under the dashboard or power distribution center).
2. Connect the red, brown, and black wires from the Vehicle Interface Cable/Non-ECM, Device Power Only Cable leads to the vehicle as shown in the ["Electrical Connection Overview Diagram" on page 21](#). Be sure to follow the parameters for each wire, detailed above.

Connect to the Vehicle J1939 Network

You may connect to the vehicle J1939 network with the CAN Coupler, a coupling device. This device uses inductive technology to allow the event recorder to read the data on the J1939 network without any puncture, cut, or splice into the vehicle cabling.

Refer to the ["Electrical Connection Overview Diagram" on page 21](#) for the following steps.

1. Connect the CAN Coupler to the Device Power Cable.
2. Find a suitable location along the vehicle J1939 network backbone to insert the CAN Coupler. The CAN Coupler MUST be installed in the vehicle cab. It cannot be exposed to moisture or inclement weather conditions.

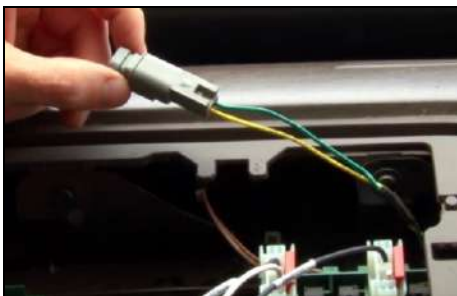

3. Untwist approximately 2 inches (5 cm) of the vehicle's J1939 wires, which are always a green and yellow twisted pair.

4. Insert the vehicle's J1939 wires into the CAN Coupler with the yellow wire on the CAN-HI (Y) side and the green wire on the CAN-LO (G) side. Ensure that the wires are secured in the tabs provided and properly oriented.

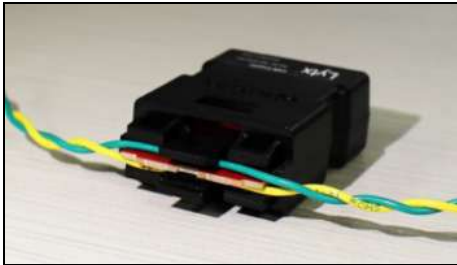

5. Place the cap on the CAN Coupler.

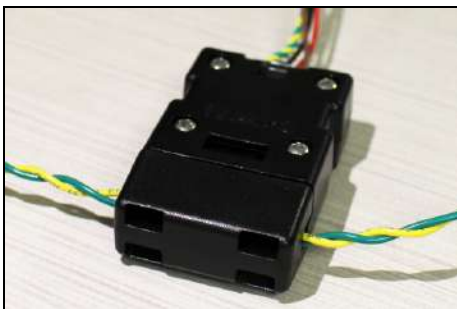

Connect Turn Signals and Brake Inputs (ER-SF300 devices only)

Before You Begin

- Refer to the manufacturer-specific connection guide for possible locations to find turn signal and brake inputs.
- Check with the vehicle manufacturer to determine if brake data is reported on the J1939 vehicle network. Brake data is reported on most vehicles with J1939 vehicle networks manufactured since 2008.

To install ER-SF300 devices:

1. Connect one of the remaining input wires on the Vehicle Interface Cable to the left turn signal input. Typically, the white wire is used.
2. Connect one of the remaining input wires on the cable to the right turn signal input. Typically, the purple wire is used.
3. Cap off and coil the remaining unused wire. If the white and purple wires were connected above, the blue wire should be capped off and coiled.

4. Using a voltmeter/multimeter, test the connections.

For turn signals, the input must cycle between 0V and 12V/24V when activated.

CAUTION: Make sure 12V/24V is only shown when the turn signals are on, NOT when the parking brake or brakes are engaged/disengaged.

Route the Device Power Cable

WARNING: Make certain that neither the cable nor your installation activities interferes with any airbag-related mechanisms or otherwise risks affecting airbag deployment. Consult the vehicle manufacturer for the location of any airbag sensors and systems and restrictions that may apply.

CAUTION: Before proceeding, you may need to remove the window and door trim to route the cable underneath. These typically snap on and off using special clips. In vehicles with side and curtain airbags, the clips are often one-time use and may need to be replaced after removal. Please refer to the vehicle service manual for information.

1. Route the end of the power cable from the connection points to the device, securing the cable at least every 30 cm/300 mm and behind panels where possible.

WARNING: Be very careful working around vehicle airbags. Please refer to the vehicle's service manual for information.

WARNING: Route the cable in a manner that protects it from damage.



2. Connect the event recorder connector to the event recorder. Place the Tamper Prevention Clip behind the connector and secure it using the T-8 screw. Loosen the screws to tilt the device so installation of the locking screw is easier.



3. Make sure the cable is clear of any sharp edges, moving parts, and cannot get pinched in the door jamb.
4. Make sure the cable is tucked away and secured so that it cannot come loose. Lytx recommends using cable-ties at least every foot, or as necessary, along the route of the cable to secure it in place.

Run Testing and Complete Installation

Testing is important to make sure the device is connected to the vehicle systems properly and that no active faults exist in the vehicle system.

Completion of the installation consists of these subsections:

Test Event Creation and Upload	31
Test Wire Connections and Settings in the Lytx Installation Tool	31
Camera Measurements (ER-SF300 devices only)	32
Initiate Diagnostic Mode	33
Complete Installation	34
Conduct Final Checks	34

Test Event Creation and Upload

1. Key the ignition to ON.
2. (For installations with the Vehicle Interface Cable only) Plug the Vehicle Interface Cable into the Device Power Cable.
3. Observe the event recorder. The center LED status light should turn green, then turn off. The lights then light up from left to right twice, indicating the device is booting. The center LED light then turns solid green.



4. Press either blue button on the unit to manually create an event. The LED status lights will light up green one by one from left to right until all are lit (lasts ~10 seconds). Confirm this light pattern.



5. Manually upload the event to Lytx:
 - a. Press and hold one of the blue buttons on the device. The center LED light starts green, disappears, and then re-appears green. Let go when it re-appears.
 - b. If upload is successful, all LED status lights will light up one-by-one from left to right, each light going from blinking to solid green.
 - c. If upload is unsuccessful (i.e. you receive a different LED status light pattern), the upload must be attempted again. There are some instances where upload is not possible due to cellular coverage and the installation is still okay. After success or failure, the center LED light turns green.
6. Repeat the manual upload process above.

Test Wire Connections and Settings in the Lytx Installation Tool

Prior to Testing

To test wire connections and settings, the Lytx Installation Tool must first be installed on your laptop. If this hasn't already been done, follow the instructions in ["Download and Install the Lytx Installation Tool"](#) on page 12.

In addition, you must also obtain the correct job file. Obtain this from the client's Implementation Services Specialist.



To finish testing, connect the device to the Lytx Installation Tool.

1. Connect a Windows laptop running the Lytx Installation Tool program to the SF-Series event recorder with the micro USB cable.

Note: You may use a micro USB cable up to 3 feet in length to make this connection.



2. Launch the Lytx Installation Tool and follow the instructions and prompts. Ignition and the vehicle J1939 connection (via engine RPM) can be verified with this program.
3. After completion, disconnect the micro USB cable.

Camera Measurements (ER-SF300 devices only)

While testing in the Lytx Installation Tool, you must take and enter the measurements below. Measurements must be entered in whole centimeters (cm).

Tip: If you're measuring in inches (in), convert to cm using: # of in x 2.54 = # of cm. Convert any fractional inches to decimal first before calculating the cm.

1. **Vehicle Width:** Distance between the outer sides of the front tires.
2. **Camera Offset:** Distance from centerline of windshield to the center of the forward-facing lens.
 - a. Typically, the centerline is marked along the top of the glass. If it isn't, measure the entire windshield first and use the midpoint as the centerline.
 - b. If the camera is to the right of center, record it as a positive number. If the camera is to the left of center, record it as a negative number.

3. **Camera Height:** Distance from the ground to the center of the forward-facing lens.
 - a. Measure the distance from the ground outside to the floor of the cab and record the number.
 - b. Measure from the floor of the cab to the forward-facing lens. If needed, you can measure from the floor to the dash, then from the dash to the camera.
 - c. Add the measurements together.



Initiate Diagnostic Mode

1. Press and hold either of the blue buttons on the device until the 3 center LED status lights turn blue (hold for about 30 seconds). After they light up, let go of the button.
2. Immediately press and hold the blue button again for up to 45 more seconds. First, the device's center LED light turns green. Then all 7 LED lights turn blue. When they turn blue, let go of the button.
3. Verify the LED status light sequence:
 - a. First, all lights turn off.
 - b. The center LED light turns green.
 - c. All LED lights turn red.
 - d. (For power-only installations) The first 3 LED lights turn green individually. These lights verify the proper function of various device components.
 - e. (For installations with J1939 vehicle network connections) The first 4 LED lights turn green individually. These lights verify the proper function of various device components.

4. After 4 minutes, the device exits Diagnostic Mode. Verify the center LED light turns green.

Troubleshooting in Diagnostic Mode

If you run into any issues in Diagnostic Mode, take the troubleshooting steps in ["Troubleshooting in Diagnostic Mode" on page 47](#).

If issues persist after troubleshooting, please contact the Lytx Technical Support Center at 925.732.4246 or email support@lytx.com.

Complete Installation

1. Finalize all electrical connections. Use cable-ties to bundle and secure all wires.
2. Replace any trim pieces on the door pillar and dash that were removed.
3. Make sure the cable is routed safely and cannot get pinched in any moving parts.
4. Reaffirm you have taken the appropriate safety precautions while working around vehicle airbags.
5. Keep this guide in a safe place for future use.

Conduct Final Checks

After installation of the SF-Series device but **prior to any operation of the vehicle, check all vehicle system lights, signals, and any other devices** (such as electronic log devices systems or CB radios) to make sure they are working properly.

Minimum checks should include the following (consult the vehicle manufacturer's service manual for additional checks that must occur):

1. **Constant power:** Ensure the event recorder is powered when the ignition is off (12V/24V to red wire).
2. **Switched power:** Confirm 12V/24V to the brown wire when the ignition is on.
3. **Ground:** Ensure the black wire is connected to a solid grounding point in the vehicle with no paint or rust.
4. **Event creation:** Turn the vehicle on and press either blue button on the event recorder. Confirm an event is created by verifying the LED's light up green from left to right, one by one.



5. **Manually upload events to Lytx:**
 - a. Press and hold one of the blue buttons on the device. The center LED light starts green, disappears, and then re-appears green. Let go when it re-appears.
 - b. If upload is successful, all LED status lights will light up one-by-one from left to right, each light going from blinking to solid green.



- c. If upload is unsuccessful (i.e. you receive a different LED status light pattern), the upload must be attempted again. There are some instances where upload is not possible due to cellular coverage and the installation is still okay. After success or failure, the center LED light turns green.
6. Turn the ignition on and let the vehicle run for 5 minutes. While holding the brake, cycle the transmission to Drive, then Reverse and then back to Park. Verify that there are no new error codes or Check Engine lights.
7. Test the other vehicle components on the power circuit of the SF-Series device to confirm their functionality, especially if the circuit is shared.
8. Verify and diagnose all active faults in the vehicle system, other devices, and the SF-Series device prior to completing the installation.
9. Place the driver safety card and the warning card included with the event recorder packaging on the driver's seat.
10. Place the decal indicating the vehicle is equipped with a recording device on the driver's seat. The customer is responsible for visibly displaying this decal.

Installation of Optional Parts

This section provides installation instructions for optional parts. Installation of the following parts are covered in this section:

- Overhead Mounting Bracket
- Extended Mounting Arm
- Remote Push Button

Overhead Mounting Bracket Installation Procedures

The optional **Overhead Mounting Bracket** allows you to mount the event recorder from the ceiling or bulkhead above the vehicle windshield.

This may be used if either:

- The recommended Standard Mounting Bracket is not feasible in the specific vehicle; OR
- Windshield mounting is restricted in the jurisdiction.



Materials

Provided:

- Overhead Mounting Bracket
- Screws

NOT provided: Drill

Attach the Overhead Mounting Bracket and Event Recorder

Mounting Location Warnings

When selecting the mounting location, heed the following warnings:

- Follow the guidelines specified in the section, "[Review Mounting Location Guidelines](#)" on page 16.
- Check that the mounting surface can be safely drilled. Do not drill or screw into wires or other components.
- Check that nothing blocks the interior- or exterior-facing lenses. Objects such as large sun visors, window tint, and circulation fans may block the lenses.

1. Attach the event recorder to the Overhead Mounting Bracket using the Torx screws. However, keep the screws loosened so the event recorder can rotate in the bracket.
2. Find a suitable mounting location in the ceiling or bulkhead. Position the assembly as close to the windshield and center of the vehicle as possible.

- a. Make sure the event recorder does not block the driver's view of the road.
- b. Make sure the exterior-facing lens has a clear view out the windshield. Turn on the wiper blades to be sure the lens is in the path of the wiper blades.
- c. Make sure the interior-facing lens cannot be blocked by any nearby objects. Rotate mirrors, sun visors, and other objects, if necessary.
- d. Make sure the mounting surface is solid, can be safely drilled, and the bracket attached securely with screws.

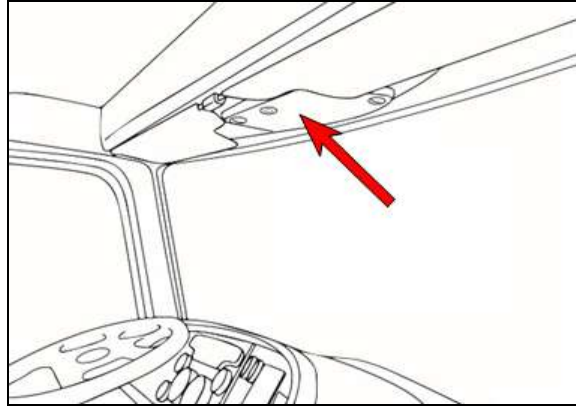

3. Mark the position of the bracket and pre-drill the screw holes. Be careful not to drill or screw into wires or other components.
4. Detach the event recorder from the bracket.
5. Screw the bracket into the marked position.
6. Re-attach the event recorder into the bracket. Adjust the event recorder so it hangs vertically (plumb). Then, secure it fully in the bracket.

After you've finished installation of the Overhead Mounting Bracket, proceed to ["Connect Electrical Wiring" on page 19](#).



Extended Mounting Arm Installation Procedures

The optional **Extended Mounting Arm ("Mounting Arm")** provides greater flexibility for device placement when windshield mounting is not available/possible. The Mounting Arm allows you to install the device on the dashboard, the ceiling, or the bulkhead.

However, the Mounting Arm is less stable than either the Standard Mounting Bracket or the Overhead Mounting Bracket. **The Mounting Arm should therefore only be installed if neither the Standard Mounting Bracket nor the Overhead Mounting Bracket are feasible options for installation.**

Materials

Provided: Extended Mounting Arm

NOT provided:

- Four (4) #10 screws (Screw length may vary by vehicle but must be long enough to ensure a secure mount.)
- Screwdriver
- T-27 security Torx bit
- Zip-ties
- Pen OR pencil

Mounting Arm Overview

The Mounting Arm may be mounted in a variety of locations due to its versatile design comprised of rotating bracket casing and pivoting balls and sockets.

1. Rotating bracket casing
2. Pivoting balls and sockets
3. Torx adjustment screws
4. Cap and device attachment screw
5. Base (detachable)

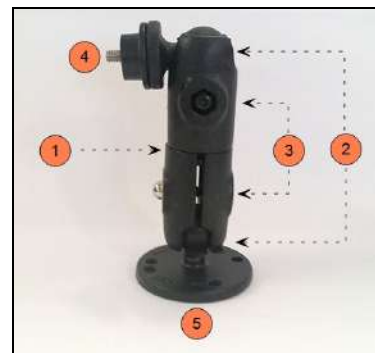

Alternative Mounting Locations

The following are alternative mounting locations for the Mounting Arm. Please select the best location based on the particular vehicle and the mounting location guidelines set forth in the section, ["Review Mounting Location Guidelines" on page 16.](#)

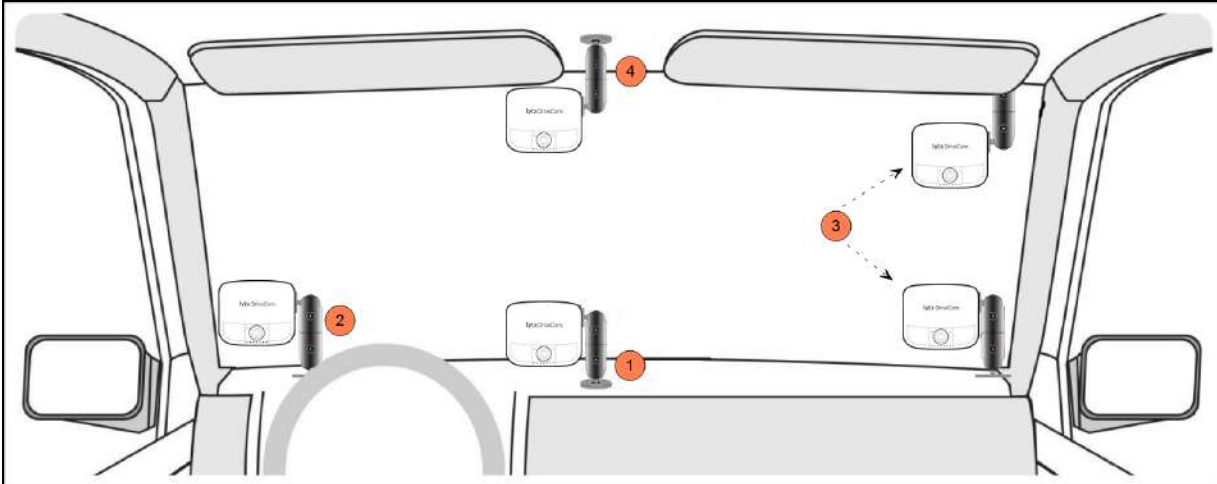

1. **Center dashboard**
2. **Lower corner, driver side dashboard**
3. **Upper or lower corners, passenger side**

Note: If the event recorder is installed in a location outside of the comfortable reach of the seated driver, the Remote Push Button should be installed as well to allow the driver to manually record an event.

For details on installing the Remote Push Button, refer to the section, ["Remote Push Button Installation Procedures"](#) on the next page.

4. **Center overhead (ceiling or bulkhead)**

You should only use the Mounting Arm in this location if use of the Overhead Mounting Bracket is not feasible.

Installation Instructions

WARNING: Do not extend the Mounting Arm's length beyond its intended design. This causes instability, which may result in excessive "non-events" being recorded.

WARNING: The Mounting Arm must be oriented vertically (straight up or down) for adequate stability.

WARNING: When selecting the mounting location, check that the mounting surface can be safely drilled. Do not drill or screw into wires or other components behind the mounting surface that can be damaged.

CAUTION: When selecting the mounting location, check that nothing blocks the interior- or exterior-facing lenses. Objects such as large sun visors, window tint, and circulation fans may block one of the lenses and should be avoided. Also check that the device does not block the driver's line of sight in the selected mounting location.

1. Using the T-27 security Torx bit, loosen the Torx adjustment screws on the Mounting Arm until the balls can pivot freely in the sockets and the two halves of the bracket casing can be rotated.
2. Screw the Mounting Arm's device attachment screw into the **right side of the event recorder**.
3. Find a suitable mounting location. Pivot/rotate the Mounting Arm and position it in various locations within the vehicle to determine the best placement. The Mounting Arm must be oriented vertically (straight up or down) for adequate stability.
4. When you have found the best location, mark the position of the base and the screw holes with a pen or pencil. At least 4 screws must be used in opposite corners of the base (shown on right).
5. Detach the base from the Mounting Arm. Loosen the adjustment screw enough so the ball can be pulled from the lower socket.
6. Attach the base securely to the marked position. Pre-drill the screw holes. Then screw the base into the marked position.
7. Re-attach the Mounting Arm to the base.
8. Pivot/rotate the assembly until the event recorder is in the desired position. Then tighten the screws. Make sure the assembly is firmly secured.
9. The Device Power Cable must be secured to the Mounting Arm with zip-ties.



After you've finished installation of the Mounting Arm, proceed to ["Connect Electrical Wiring" on page 19](#).

Remote Push Button Installation Procedures

The optional **Remote Push Button** allows drivers to manually record events using a push-button switch mounted in an easy-to-reach location, such as the dashboard. This is useful for drivers of larger vehicles in which the SF-Series event recorder is positioned out of reach of the driver's seat, preventing them from easily pushing one of the manual record buttons on the event recorder when seated in the driver's seat.

Installation of the Remote Push Button contains the following subsections:

1. Mount the Remote Push Button
2. Assign the Input in the Lytx Installation Tool

Materials

Provided:

- Remote Push Button - Standard

NOT provided: Hole saw or stepped cone cutter

Mount the Remote Push Button

1. Find a suitable mounting location for the button:
 - a. Standard size: The location must be within a fixed panel with space for a 0.75-inch hole. There must be 2.75 inches of clearance behind the panel.
 - b. The location should allow the driver to easily push the button while seated in the driver's seat.
 - c. The button should not be placed where the driver may accidentally push the button.
2. Using a hole saw/stepped cone cutter, drill a hole into the panel.
3. Bring the Remote Push Button assembly through the hole and connect it to the Vehicle Interface Cable/Non-ECM, Device Power Only Cable. Refer to the ["Electrical Connection Overview Diagram" on page 21](#).
4. Mount the button into the hole. Secure it from the inside with the hex nut.

For Standard size:



Assign the Input in the Lytx Installation Tool

To complete installation of the Remote Push Button, its input must be properly assigned in the Lytx Installation Tool.

To assign the input:

1. Go to the Assign Device Inputs screen in the Lytx Installation Tool.
2. Assign GIO C (Blue) to *Remote Record Button*.
3. Test the installation. Press either blue button on the device to manually record an event. The LED status lights on the SF-Series device will light up green one-by-one from the left to right until all are lit, indicating the test was successful



Note: After assigning the Remote Push Button, the Lytx Installation Tool may take up to several minutes to detect the assignment. Please wait for detection before troubleshooting.



Maintenance & Troubleshooting

THE DEVICE SHOULD BE INSTALLED AND MAINTAINED BY QUALIFIED TECHNICIANS. Only a properly qualified technician should install and maintain the SF-Series device. Any electrical work should be performed only by an ASE (minimum T6 & L2), MECP or equivalent certified technician with an expertise in installing and troubleshooting advanced vehicle onboard components including multiplexed circuits. Lytx, Inc. disclaims all responsibility for any damages arising from improper installation and maintenance of the SF-Series device.

Maintenance

After installation has been completed, Lytx recommends inspection and maintenance be performed every time normal preventative maintenance is performed on the vehicle and anytime the Lytx Vehicle Event Recorder or its wiring and electrical connections are moved, re-installed or otherwise altered from their initial installation.

Take these steps:

1. **Visually inspect all electrical cables for pinches, fraying or wear.** Electrical cables that are pinched or frayed may be found on vehicles where the electrical connection was incorrectly installed. Further, cables and wires may become worn or exposed over time due to contact with sharp edges or objects and when impacted by other electronic work, mechanical work, or installations. If any actual or potential cable/wire damage is detected, necessary repairs should be performed, potentially including re-installation of the Lytx device.
2. **Visually inspect all electrical connections to ensure they are fully secured.** Electrical connections may not be fully secured if the connection was incorrectly installed. They may also be loosened when impacted by other electrical work, mechanical work, or installations.
3. **Visually inspect all wire and wire terminations to ensure they are proper and undamaged.** Ensure that all wiring is undamaged and that all wire terminations are in conformance with the suggestions set forth in ["Wiring and Wire Termination Suggestions" starting on page 23.](#)

Troubleshooting Installation Issues

If you're having difficulty troubleshooting or problems persist after taking the recommended steps, please contact the Lytx Technical Support Center at 925.732.4246 or email support@lytx.com.

Problem	Possible Causes and Solutions
<p>The SF-Series device is not booting properly. The device briefly connects to the Lytx Installation Tool, then disconnects.</p>	<p>There may be insufficient current on the constant power connection. Check that connection. Ensure the source wire is capable of supplying 5 amps.</p>
	<p>There may be a loose or insufficient chassis ground. Inspect the ground connection to ensure it's tight and it's in a location free of paint or rust.</p>
<p>The SF-Series device does not connect to the laptop at all.</p>	<p>There may be an issue with that specific USB port. Try connecting to a different USB port on the laptop.</p>
	<p>The laptop may not be detecting the device. Open Device Manager on your laptop. Verify that "Remote NDIS6 based Device" shows up under "Network Adapters".</p>
	<p>There may be an issue with the brown wire connection. Check the wire for damage. Gauge the wire with a voltmeter for 12V/24V with the ignition on. Check the vehicle fuse for that circuit.</p>
<p>The Model and Device Serial Number do not appear in the Lytx Installation Tool.</p>	<p>There may be an issue with Windows Firewall. Plug the device in again and verify that the Lytx Installation Tool is allowed through Windows Firewall.</p>
<p>The Lytx Connection is not being detected in the Lytx Installation Tool.</p>	<p>Perform a forced check-in: Hold one of the blue buttons for 10 seconds. Verify the LED light pattern. The lights will light up and blink green one-by-one from the left to right until all are lit, indicating the check-in was successful.</p>
	<p>The device may be in an area without reception. Bypass this for now by checking the "Known Issue Bypass" box. Re-test this connection when the device is in a location with better reception.</p>
<p>Ignition is not being detected in the Lytx Installation Tool.</p>	<p>If the engine is already turned on, turn the engine off and then back on. Wait about 10 seconds for the ignition to be detected.</p>
	<p>There may be an issue with the brown wire connection. Check the wire for damage. Gauge the wire with a voltmeter for 12V/24V with the ignition on. Check the vehicle fuse for that circuit.</p>
	<p>Wait about 10 seconds. Then verify that the ignition is being detected.</p>



Problem	Possible Causes and Solutions
Engine RPM is not being detected in the Lytx Installation Tool.	Ensure the vehicle is running. Turn the device off and on either by disconnecting the Device Power Cable or by entering the device's Diagnostic Mode. For more detail on entering Diagnostic Mode, go to "Initiate Diagnostic Mode" on page 46 .
	If the installation does not include connection to the vehicle network, bypass this.
	J1939 Connections: The wires may be reversed over the CAN Coupler. Ensure that the Yellow wire is on the CAN_HI (Y) side of the Coupler and the Green wire is on the CAN_LO (G) side.
	J1939 Connections: Ensure that the CAN Coupler connector is fully engaged.
	J1939 Connections: The CAN Coupler may not have been placed on the J1939 backbone but on a stub. Try moving the Coupler to a different location.
The turn signal or brake inputs aren't being detected in the Lytx Installation Tool.	Verify the inputs are correctly assigned in the Lytx Installation Tool. Check the connection point and inspect the corresponding wiring for cuts or damage.
The GPS time and coordinates are not being detected OR only zeroes are detected in the Lytx Installation Tool.	The device may be in an area with poor reception. Try relocating to a different area and re-testing the signal.



Problem	Possible Causes and Solutions
<p>The device fails to power up after installation.</p>	<p>The vehicle battery may be disconnected. Reconnect the battery or check the battery cut-off switch.</p>
	<p>Ensure the red wire on the Vehicle Interface Cable/Non-ECM, Device Power Only Cable is connected to a constant power source.</p>
	<p>The fuse may be missing or open. Check the fuse panel location for constant power. Ensure the proper value fuse is installed and not open.</p>
	<p>(For installations with a Vehicle Interface Cable) The connection between the Device Power Cable and the Vehicle Interface Cable may not be fully secured. Check the connection. Disconnect and reconnect the cables, ensuring the connection “snaps”.</p> <p>Note: The Device Power Cable connector into the event recorder has a locking tab. To disconnect, push in the locking tab before pulling out. Failure to do so may cause damage to the device.</p>
	<p>The red wire on the Vehicle Interface Cable/Non-ECM, Device Power Only Cable may be damaged. Check the entire length of the wire for damage/cuts. Fix any issues.</p>
<p>The SF-Series device does not come out of Hibernation mode when the ignition is activated.</p>	<p>There may be an issue with the brown wire connection. Check the wire for damage. Gauge the wire with a voltmeter for 12V/24V with the ignition on. Check the vehicle fuse for that circuit.</p>
<p>The SF-Series device boots up and displays a solid Yellow LED status light.</p>	<p>Contact Lytx Technical Support. The device must be returned.</p>

Troubleshooting Issues After Installation

Lytx event recorders have built-in diagnostic tools to help troubleshoot issues you may experience. If you're having issues with the SF-Series event recorder, initiate the device's Diagnostic Mode. In this mode, the device's LED status lights will help identify the specific component of the device that may be causing the issue.

This section provides instructions on how to initiate the Diagnostic Mode, definitions of each of the device's LED status lights, and steps for troubleshooting.

To initiate the Diagnostic Mode, the device must be rebooted. After the reboot sequence is finished, the device will enter the Diagnostic Mode.

Initiate Diagnostic Mode

To initiate the Diagnostic Mode on the SF-Series device, you must first reboot the device. To reboot the SF-Series device, follow these steps:

1. Press and hold either of the blue manual record buttons on the device until the 3 center LED status lights turn blue (hold for about 30 seconds). After they light up, let go of the button.



2. Immediately press and hold the manual record button again for up to 45 more seconds until all 7 LED status lights turn blue. After they light up, let go of the button. At this point, the SF-Series will begin rebooting.



LED Status Light Sequence: Reboot

1. As the device shuts down, all LED status lights will shut off.



2. As it starts back up, the center LED status light will turn green.



- Once the device has fully restarted, it will enter Diagnostic Mode. To start, all LED status lights will turn red.

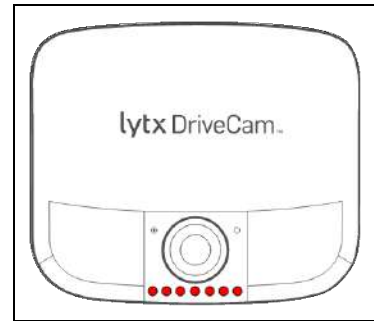

Note: The device may be rebooted a maximum of 7 times in a 24-hour period.

Troubleshooting in Diagnostic Mode

Diagnostic Mode reveals issues with the device. Each of the LED status lights provides the status of a different component of the device as shown below.

Please note:

- All LED status lights will turn red to start. Each LED will turn green when/if the corresponding feature is confirmed as working properly.
- In Diagnostic Mode, the LED status lights will not turn any colors other than green or red. (Except for LED 2, which may also turn yellow.)
- The device will stay in Diagnostic Mode for 4 minutes. Pay attention to the LED status lights during this time.

	Color	Status
	Green ●	OK
	Red ●	Error - requires troubleshooting
(For LED 2 only) Yellow ●	Error - requires troubleshooting	

LED	Component	Troubleshooting Steps
1	Vehicle ignition	If the engine is already turned on, turn the engine off and then back on. Wait about 10 seconds for the ignition to be detected.
		There may be an issue with the brown wire connection. Check the wire for damage. Gauge the wire with a voltmeter for 12V/24V with the ignition on. Check the vehicle fuse for that circuit.
2	GPS	The device may be in an area with poor reception. Try re-locating to a different area and re-testing the signal.
3	Cellular signal	Wait for the device to exit Diagnostic Mode (up to 5 minutes). Perform a forced check-in: Hold one of the blue buttons for 10 seconds. Verify the LED light pattern. The lights will light up and blink green one-by-one from the left to right until all are lit, indicating the check-in was successful.
		The device may be in an area with poor reception. Try re-locating to a different area and re-testing the signal.
4	Vehicle network data (ECM) (Only for installations including vehicle network connections)	Start the vehicle. Ensure the vehicle is running.
		J1939 Connections: The wires may be reversed over the CAN Coupler. Ensure that the Yellow wire is on the CAN_HI (Y) side of the Coupler and the Green wire is on the CAN_LO (G) side.
		J1939 Connections: Ensure that the CAN Coupler connector is fully engaged.
		J1939 Connections: The CAN Coupler may not have been placed on the J1939 backbone but on a stub. Try moving the Coupler to a different location.
5	Brakes	(Standard) If brakes are read from the vehicle network (ECM), follow troubleshooting steps for the ECM connection (above).
		For hard-wired brakes, verify that the Brake Signal is properly assigned in the Lytx Installation Tool.
		For hard-wired brakes, check the connection point and inspect the corresponding wiring for cuts or damage.
6	Left turn signal	Verify that the Left Turn Signal is properly assigned in the Lytx Installation Tool.
		Check the connection point and inspect the corresponding wiring for cuts or damage.
7	Right turn signal	Verify that the Right Turn Signal is properly assigned in the Lytx Installation Tool.
		Check the connection point and inspect the corresponding wiring for cuts or damage.

Uninstalling the Device

If you must uninstall the device for any reason, follow the guidance and instructions below.

EXPLOSION HAZARD: Do not disconnect equipment unless power has been removed and the area is known to be non-hazardous.

WARNING: Make certain that neither the cable nor your installation activities interferes with any airbag-related mechanisms or otherwise risks affecting airbag deployment. Consult the vehicle manufacturer for the location of any airbag sensors and systems and restrictions that may apply.

CAUTION: Before proceeding, you may need to remove the window and door trim to remove the cable underneath. These typically snap on and off using special clips. In vehicles with side and curtain airbags, the clips are often one-time use and may need to be replaced after removal. Please refer to the vehicle service manual for information.

CAUTION: Do not try to pull or pry the bracket off the windshield. Doing so may cause damage to the windshield.

Materials

- Torx wrench OR screwdriver with T-27 and T-8 Torx bits
- 3M Tape Removal Tool OR a broad, very thin putty knife
- WD-40 OR a similar lubricant

Instructions

Before you begin, review the ["Electrical Connection Overview Diagram"](#) starting on page 21 for a summary of the existing installation.

1. Turn off the vehicle ignition and remove the key.
2. Remove the screws on each side of the device. Detach the device from the bracket.
3. Remove the security screw and the Tamper Prevention Clip on the back.



4. Push in the locking tab on the power cable and disconnect. Note that failure to push in the locking tab may cause damage to the device.

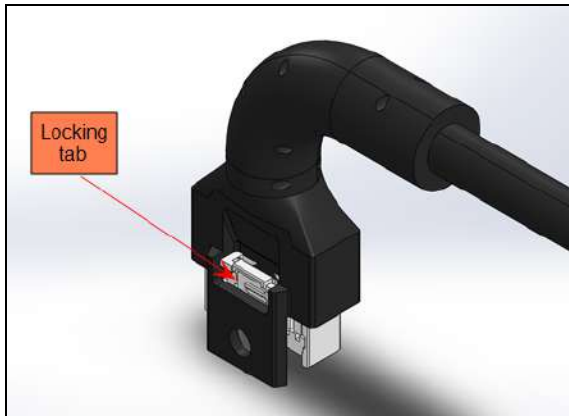

5. Using the 3M Tape Removal Tool or putty knife, apply a small amount of WD-40/lubricant to both sides of the blade. Carefully remove the bracket from the windshield.
6. Carefully remove the power cable and wiring harness, which are tucked behind different interior panels. Remove any panels, as needed. (Typically, the cable and harness run underneath the headliner and down the A-pillar.)

WARNING: Be very careful working around vehicle airbags. Please refer to the vehicle's service manual for information.

7. Locate the existing connection points in the vehicle fuse panel. Follow the path of the harness or consult the vehicle manufacturer's manual to find the fuse panel. (Typically, the panel is located underneath the dashboard on the driver's or passenger's side.)
8. Disconnect all wires from their connection points. Return the connection points to their original factory condition or restore them so they are secure and may be used again in the future.

For more detail on the connection points, refer to the ["Electrical Connection Overview Diagram" starting on page 21](#) and subsequent sections.

WARNING: Do not leave any exposed wire near connectors.

9. If the harness is connected to an optional CAN Coupler, remove the cap on the CAN Coupler. Remove the wires inside.

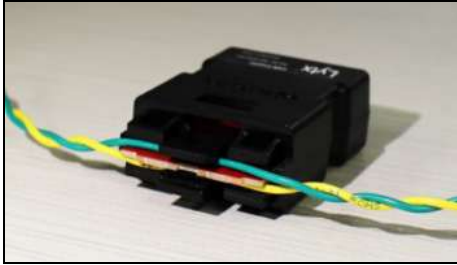

Contact Technical Support

For troubleshooting support, please contact the Lytx Technical Support Center at 925.732.4246 or email support@lytx.com.

Installation Support Hours:

- Monday - Friday: 7am - 8pm EST
- Saturday - Sunday: 8am - 6pm EST